



SCC2000A-EV

ELECTRIC CRAWLER CRANE



■ www.sanygroup.com

QUALITY CHANGES THE WORLD

The parameters, pictures and standard/optional equipment are only for reference in this brochure. The actual machine is based on the effective price list and contract.

V1.0

01

04 / INTRODUCE

04

08 / TRANSPORT DIMENSION

02

06 / OUTLINE DIMENSION

05

10 / TRANSPORT PLAN

03

07 / MAIN PERFORMANCE
PARAMETERS

06

12 / CRANE INTRODUCTION
Product Specification
Safety Device

07

16 / WORKING CONDITIONS

H configuration
FJ configuration
LJ configuration

01 | Introduce

200t

Max. lifting capacity

86m

Max. boom length

**59m+24m/
53m+30m**

Max. fixed jib combination

59m+63m

Max. luffing jib combination

Energy Saving and Environmental Protection

- Pure electric, low emission, environmentally friendly and energy efficient.

Extended Battery Range

- Equipped with 422kWh high-capacity power battery, supporting 8h long time operation.

Lower Operating Cost

- Reduces energy consumption costs by 37% compared to traditional fuel engine models and eliminates engine maintenance expenses.

Safe and Reliable

- High voltage safety design, real-time insulation monitoring by Battery Management System, capable of actively disconnecting high voltage in the event of sudden leakage, third-generation intelligent control system, one-button start/stop, 10.1-inch dual touchscreen display, intelligent and convenient.

Fast Charging

- Supports 120kW DC charging, charging time < 2h.
- 10kW, 20kW, 40kW, 80kW (optional) AC charging modes are available for customers, applicable to all site power configurations.

High Adaptability

- Equipped with lower structure charging port, allowing an operation with charging plug in, meeting various customer usage scenarios.



SCC2000A-EV

ELECTRIC CRAWLER CRANE



02 | Outline Dimension



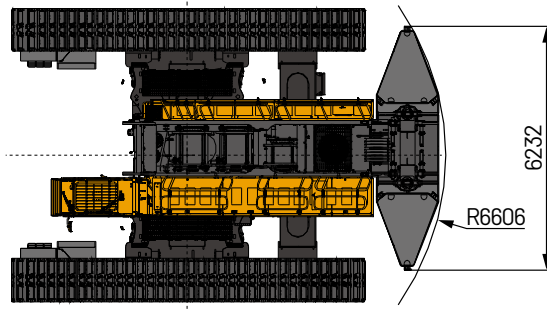
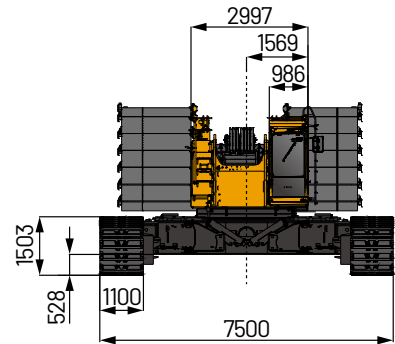
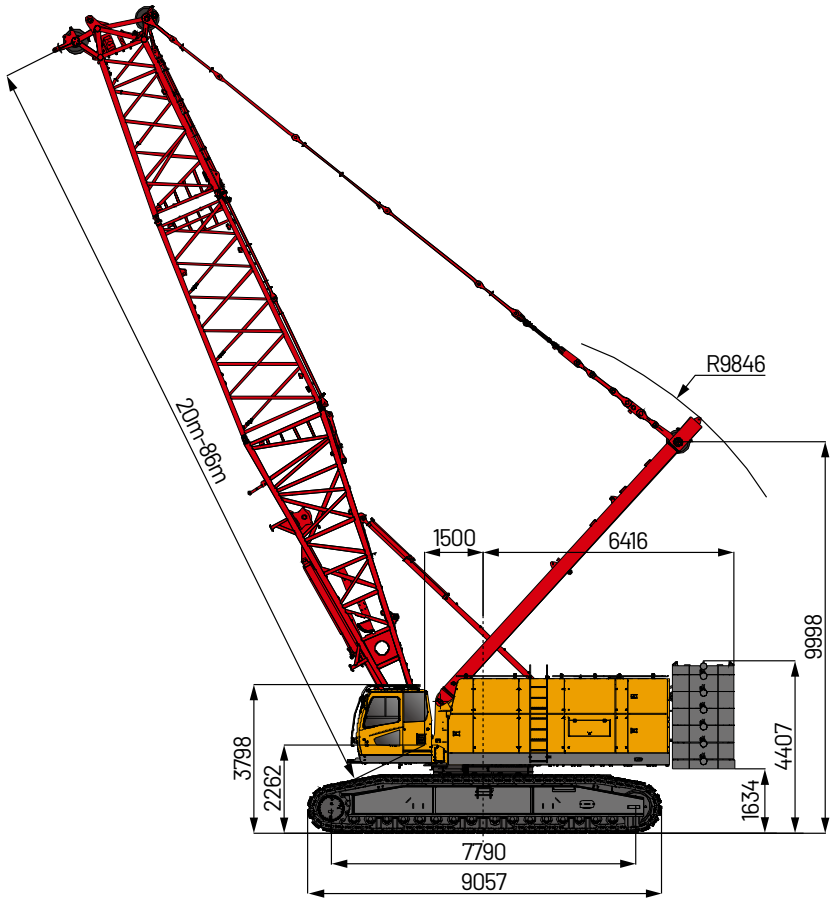





SCC2000A-EV
Unit: mm

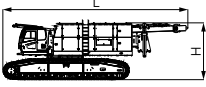
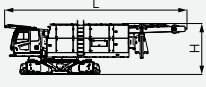

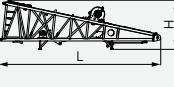

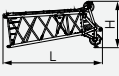
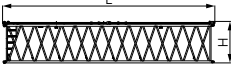

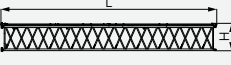
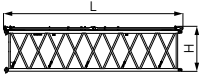
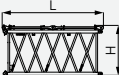

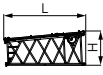

03 | Main Performance Parameters

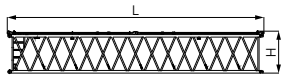
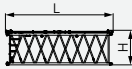
Performance Indicators	Unit	Parameter
Boom Configuration		
Max. lifting capacity	t	200
Max. lifting moment	t·m	1304
Boom length	m	20~86
Boom luffing angle	°	30~85
Fixed Jib Configuration		
Max. lifting capacity	t	34
Jib length	m	15~30
Longest boom + longest fixed jib	m	59+24/53+30
Fixed jib angle	°	15,30
Luffing Jib Configuration		
Max. lifting capacity	t	80
Jib length	m	18~63
Longest boom + longest fixed jib	m	59+63
Luffing jib angle	°	15~75
Operation Speed		
Rope speed of main/aux. winch	m/min	0~140
Rope speed of boom hoist winch	m/min	0~76
Slewing speed	rpm	1.5
Travel speed	km/h	0~1.45
Wire Rope		
Main hoist wire rope: diameter × length	φ mm × m	26 × 460
Aux. hoist wire rope: diameter × length	φ mm × m	26 × 310
Rated single line pull of main/aux. hoist wire rope	t	14
Drive Motor		
Model	-	Danfoss-EM-PMI375-T1100-2100
Rated power	kW	234
Max. power	kW	445
Transport Parameters		
Weight of machine	t	195.3
Rear counterweight	t	77
Carbody counterweight	t	10 × 2
Transport weight of basic machine (with crawler frames)	t	98.3
Transport weight of basic machine (without crawler frame)	t	47.1
Machine transport dimension (with crawlers) L × W × H	mm	13239 × 7500 × 4076
Machine transport dimension (without crawlers) L × W × H	mm	12544 × 2997 × 3547
Other Parameters		
Average ground pressure (basic boom)	Mpa	0.22
Gradeability	%	30

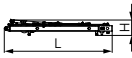
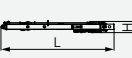
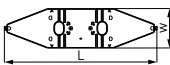
04 | Transport Dimension

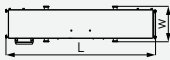
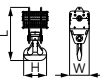
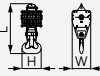
No.	Item	Shape	Length (m)	Width (m)	Height (m)	Weight (t)	Quantity
1	Basic machine 1 (with crawlers, without boom base)		13.239	7.50	4.076	98.3	1
2	Basic machine 2 (without boom base and crawlers)		12.544	2.997	3.547	47.1	1
3	Crawlers		9.048	1.777	1.501	25.3	2
4	Boom base with the jib luffing winch		9.296	2.80	2.824	6.8	1
5	6m transition insert		6.17	2.501	2.367	1.49	1
6	Boom top (with luffing pulley)		5.727	2.292	2.663	3.79	1
7	12m boom insert		12.18	2.513	2.383	2.42	2
8	6m boom insert		6.18	2.513	2.383	1.65	1
9	3m boom insert		3.18	2.513	2.383	0.93	1
10	12m fixed jib		12.152	1.807	1.541	1.30	2
11	6m fixed jib		6.152	1.807	1.541	0.71	1
12	3m fixed jib		3.152	1.807	1.541	0.42	1
13	Luffing jib base		2.811	2.49	1.756	0.89	1
14	Luffing jib top		3.818	1.805	1.979	1.58	1
15	4.5m transition insert		4.704	2.10	1.964	1.00	1

04 | Transport Dimension

No.	Item	Shape	Length (m)	Width (m)	Height (m)	Weight (t)	Quantity
16	12m luffing jib		12.18	2.142	1.985	2.1	2
17	6m luffing jib		6.18	2.142	1.985	1.24	1
18	3m luffing jib		3.18	2.142	1.985	0.8	1
19	Runner		3.104	1.292	1.152	0.74	1
20	Front mast		6.492	2.266	0.64	1.8	1
21	Rear mast		6.192	1.83	0.884	1.63	1
22	Counterweight tray		6.232	1.602	0.689	11.0	1
23	6t counterweight blocks		2.015	1.578	0.53	6.0	10
24	3t counterweight blocks		2.015	1.578	0.343	3.0	2
25	Carbody counterweight		4.813	1.132	0.593	10.0	2
26	200t hook		2.443	1.11	0.91	3.47	1
27	150t hook		2.438	0.91	0.944	2.8	1
28	100t hook		2.346	0.93	0.842	1.97	1
29	80t hook		2.206	0.91	0.644	1.94	1
30	35t hook		1.972	0.91	0.455	1.2	1
31	13.5t hook		0.949	0.425	0.425	0.47	1

05 | Transport Plan

Trailer 1	
Part (s)	<ul style="list-style-type: none"> Basic machine (ladders of machine cover are removed to transport) Outrigger pad × 4 (on the carbody)
Weight	<ul style="list-style-type: none"> 47.1t

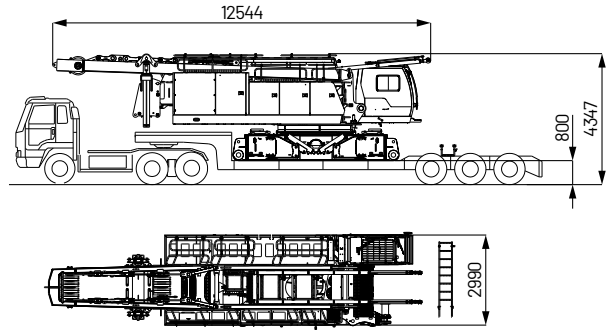

Trailer 2	
Part (s)	<ul style="list-style-type: none"> 12m boom 1 × 1 12m boom 2 × 1 12m boom 3 × 1 12m boom outer pendant bar × 2 Counterweight tray × 1 6t counterweight block × 2 3t counterweight block × 1
Weight	<ul style="list-style-type: none"> 32.5t

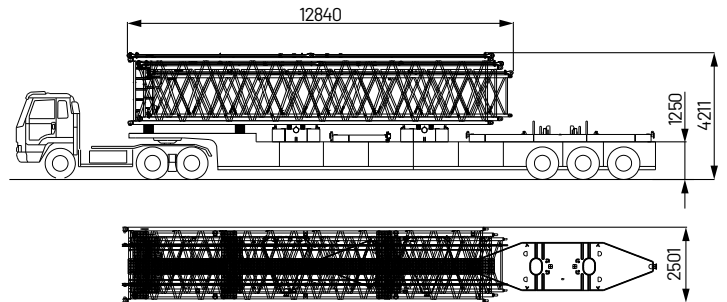

Trailer 3	
Part (s)	<ul style="list-style-type: none"> 6m boom 1 × 1 6m boom 2 × 1 6m boom 3 × 1 6m boom outer pendant bar × 1 6t counterweight block × 4 Boom base (with luffing mechanism and boom base outer pendant bar) × 1
Weight	<ul style="list-style-type: none"> 34.58t

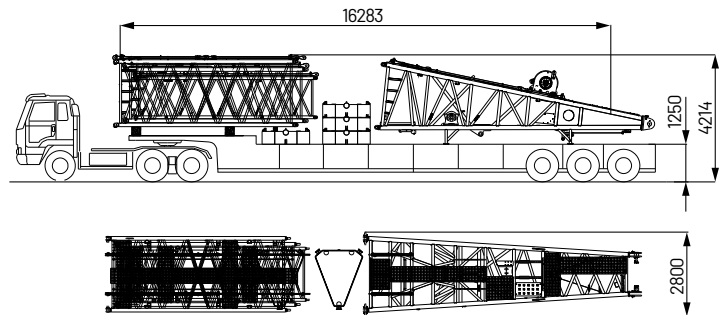

Trailer 4	
Part (s)	<ul style="list-style-type: none"> 12m boom 1 × 1 12m boom 2 × 1 12m boom 3 × 1 12m boom outer pendant bar × 1 6t counterweight block × 4 3t counterweight block × 1
Weight	<ul style="list-style-type: none"> 33.17t

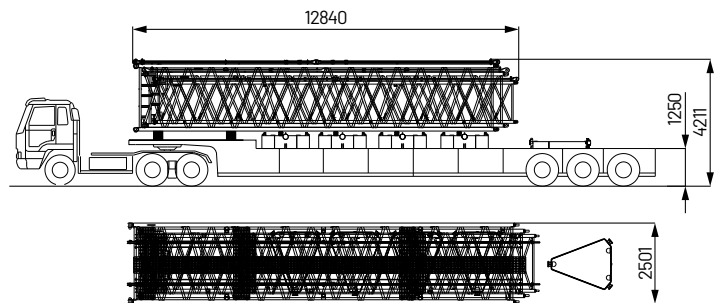

05 | Transport Plan

Trailer 5	
Part (s)	<ul style="list-style-type: none"> ▪ Boom top (with luffing guiding pulley) × 1 ▪ Carbody counterweight × 2 ▪ Luffing jib base × 1 ▪ Back-stop of luffing jib × 2 ▪ Front mast of jib × 1 ▪ Rear mast of jib × 1 ▪ Reeving winch jib components ▪ 200t hook × 1 ▪ 35t hook × 1 ▪ 13.5t hook × 1
Weight	▪ 33.26t

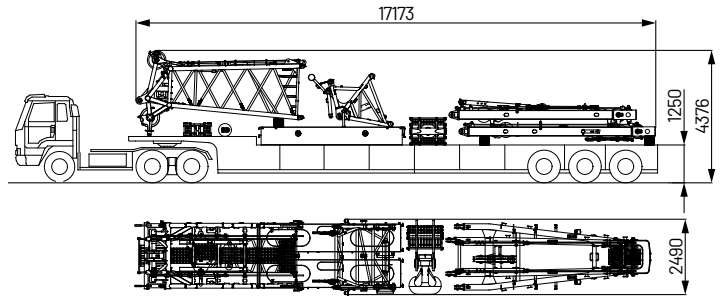

Trailer 6	
Part (s)	<ul style="list-style-type: none"> ▪ Right track frame × 1 ▪ 3m boom insert 1 × 1 ▪ 3m boom insert 2 × 1 ▪ 3m boom insert 3 × 1 ▪ 3m boom outer pendant bar × 1 ▪ Runner × 1 ▪ 150t hook × 1 ▪ Jib luffing top × 1
Weight	▪ 32.69t

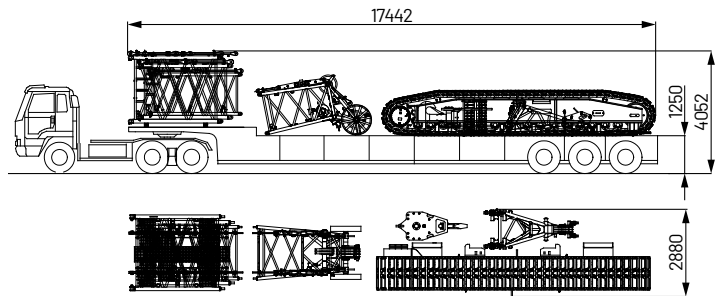

Trailer 7	
Part (s)	<ul style="list-style-type: none"> ▪ Left track frame × 1 ▪ Boom transition insert × 1 ▪ Jib transition insert × 1 ▪ Reeving winch boom components ▪ Transition insert outer pendant bar × 1 ▪ 100t hook × 1 ▪ 80t hook × 1 ▪ Tool box 1 × 1 (attachment parts, attachment tools, mid-point suspension cable of boom and mid-point suspension cable of jib) ▪ Tool box 2 × 1 (additional pendant bars of fixed jib and luffing jib, back-stop of fixed jib)
Weight	▪ 33.21t

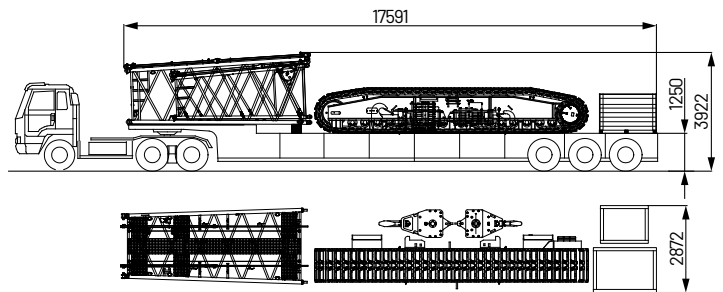

Note:

- 1) The basic machine and other components transported shall be secured on the trailer with wire rope or slings, protected with anti-wearing pads.
- 2) Do not bind the boom during transport to avoid damage. Avoid direct contact between the boom/jib tube and wire rope or other hard slings to prevent abrasion.
- 3) The transport plan in this section is for reference only. The actual plan needs to be adjusted based on the transport vehicle available and the transport codes.
- 4) The components provided in this section are standard configuration. Make adjustment based on actual components if there are optional parts, and the dimension and weight will vary accordingly.

06 | Crane Introduction

1 Product Specification

Drive Motor

- Model: EM-PMI375-T1100-2100-DUAL+IP67+RES1+CS.
- Rated power: 234kW.
- Max. power: 445kW.
- Rated torque: 1118N.m.
- Max. torque: 2125N.m.
- Max. working speed: 2680rpm.
- Working environment temperature: -40°C ~+65°C.
- Insulation class: H.
- Cooling system: Liquid cooling (50% deionized water + 50% ethylene glycol).
- Coolant flow rate: 20L/min.
- IP rating IP67.
- Weight: 295kg.
- Work shift: S1/S9.

Power Battery

- Battery type: LFP (Lithium Iron Phosphate).
- Rated capacity: 684 Ah.
- Nominal voltage: 618.24 V.
- Rated energy storage: 422.87 kWh.
- Specific energy: 155 Wh/kg.
- Battery configuration: 3* (2H01).
- Storage temperature: -30~60°C, long-term storage controlled below 35°C.
- Operating temperature: -30~65°C.
- Operating humidity: ≤90%.
- Thermal management: Liquid Heating + Liquid Cooling.
- State of charge (SOC) operating range: 8%~100%.
- Max. continuous charging current (A): 400.
- Max. continuous discharging current (A): 400.
- Discharging current at peak speed (A): 700A, 30 seconds.
- IP protection rating: Battery box IP68, junction box IP67, control box IP67.
- Total system weight (kg): 2706 kg (Battery box only).

Hydraulic System

- Main pump: Adopt high-power open variable displacement piston pump, providing power for the entire machine.
- Closed pump: Used for slewing.
- Gear pump: Single gear pump are used for heat dissipation and servo functions.
- Control: The main pump adopts the control type of electrically proportionate positive flow. The operating components are two electric-controlled cross handles, one electric control pedal valve for boom operating, and one dual electric pedal control valve for travel, to control each actuator proportionally.
- Way of cooling: Heat exchanger, fan core and multi-stage cooling.
- Filter: Large flow, high accuracy filter, with bypass valve and indicator, which can remind the user to replace the filter element in time.
- Max. pressure of system:
Main load, aux. load, and travel system: 32MPa.
Boom hoist cylinder lifting: 32MPa.
Swing system: 24MPa.
Control system: 4.5MPa.
- Hydraulic tank capacity: 1240L.

Main and Aux. Hoist Winch

- Pump and motor: Dual-placement speed-controlled, energy-efficient design. The system integrates a winch balance valve and anti-hook sliding technology, ensuring smooth lifting and lowering of loads.
- Winch brake adopts concealed, normally closed, wet type and spring loaded fin type normally engaged brake, spring force braking, oil pressure released.
- Main and aux. load hoist winches adopt piston motor of variable displacement to drive planetary reducer.

	Rope speed on the outermost work layer	0~140m/min
Main hoisting winch	Wire rope diameter	Φ26mm
	Wire rope length of main hoist	460m
	Rated single line pull	14t
	Rope speed on the outermost work layer	0~140m/min
Auxiliary hoisting winch	Wire rope diameter	Φ26mm
	Wire rope length of auxiliary hoist	310m
	Rated single line pull	14t

Luffing Mechanism

- The boom hoist winch is directly driven by a reducer. The winch handle allows bi-directional control for boom lifting and lowering.
- Drums with fold-line grooves ensure orderly wire rope reeving across multiple layers.

	Rope speed on the outermost work layer	0~76m/min
Boom hoist mechanism	Wire rope diameter	Φ26mm
	Wire rope length of auxiliary hoist	270m
	Rated single line pull	14t

Slewing Mechanism

- The slewing brake adopts concealed, wet type, spring loaded, normally-engaged brake, and braking through spring force, oil pressure released.
- Slewing system, equipped with integrated slewing cushion valve, has free slip function. It is featured in steady start, control, stop and excellent inching function.
- External gear slewing drive with 360° slewing range, and the max. slewing speed is 1.5r/min.
- Slewing lock: A cylinder lock device ensures that the superstructure can be secured in four directions after operation or during transport, enhancing convenience and reliability.
- Slewing ring: Single row ball bearing.

Counterweight

- The counterweight tray and blocks are designed to be piled up for easier assembly and transport.
- Rear counterweight composition: one tray of 11t. counterweight block I of 6t × 10. counterweight block I of 3t × 2.
- Carbody counterweight: 10t × 2.

Superstructure

- The high-strength steel welded frame structure provides better resistance to deformation and torsion. It features a closed protective cover for enhanced protection. The component layout is rational, making maintenance and service more convenient.

06 | Crane Introduction

1 Product Specification

Cab and Controls

- Novelty in cab design, artistic modeling, refined trim, and a large-area glass window with a tilt angle of 20° to broaden horizon, fitted with a low-beam headlamp and a rear-view mirror for enhanced visibility, installed with air conditioner and radio, the arrangement of seats, control handle and various control buttons is ergonomically designed to enable more comfortable operation.
- Cab layout: 10.1-inch touch screen, programmable smart switches, and improved touch screen interface.
- Armrest box: On the left and right armrest box are control handles, electrical switches, emergency stop and ignition switch. The armrest box can be adjusted along with the seat.
- Seat: Multi-way and multi-level floating adjustable seat with unload switch.
- A/C: Cooling and heating system, optimized air channels and vents.
- Multiple cameras can be displayed on the monitor simultaneously, enabling reverse video display, real-time monitoring of wire rope on each winch, conditions behind the counterweight and surrounding the machine.

Travel Drive

- Independent travel driving units are adopted for each side of the crawler, to realize straight traveling and turning driven by travel motor through gearbox and sprocket wheel.
- The crawler can be controlled separately when traveling.
- The travel speed can be controlled steplessly from 0 to 1.45km/h.
- Gradeability is 30%.

Traveling Braking

- Embedded, wet, spring-loaded and normally-closed brake, which is braking with spring force and released by oil pressure.

Crawler Tensioning

- Spring tensioner with auxiliary hydraulic cylinder regulates the tension degree through charging grease, and the spring can perform buffer and protection function when traveling.

Steering System

- It supports single-track turning and pivot turning.

Track Frame

- High-strength alloy cast steel track pad can prolong the service life. They are 1100mm wide, and the total number is 72pcs × 2.

Track Roller

- Maintenance-free track roller.

Outrigger

- Hydraulic outrigger cylinders facilitate track frame assembly and disassembly.

Boom

- Lattice structure. The chord adopts high-strength structural tube and each section is connected through pins.
- Basic boom: 9m boom base + 6m Reducing boom section + 5m boom top.
- Boom insert: 3m × 1, 6m × 1, 12m × 2.
- Boom length: 20m~86m.

Fixed Jib

- Lattice structure. The chord adopts high-strength structural tube and each section is connected through pins.
- Basic jib: 1.5m jib base + 4.5m Reducing boom section + 3m jib top + 3m luffing jib + 3m Luffing jib.
- Jib insert: 3m × 1, 6m × 1, 12m × 2.
- Fixed jib: 15m~30m.
- Longest boom+jib: 59m+24m/53m+30m.

Luffing Jib

- Lattice structure. The chord adopts high-strength structural tube and each section is connected through pins.
- Basic jib: 1.5m jib base + 4.5m Reducing boom section + 3m jib top + 3m Luffing jib + 6m Luffing jib.
- Jib insert: 3m × 1, 6m × 1, 12m × 2.
- Fixed jib: 18m~63m.
- Longest boom+jib: 59m+63m.

Tip Pulley

- Welded structure, connected with the boom through pin, and used for auxiliary hook operation.

Hook Block

No.	Capacity (t)	No. of pulleys	Weight (t)	Quantity
1	200	9	3.47	1
2	150	7	2.8	1
3	100	5	1.97	1
4	80	3	1.94	1
5	35	1	1.2	1
6	13.5	0	0.47	1

Note: the above-mentioned operating equipment is full-up configuration. The actual configurations are subject to contract.
* marked as optional material

06 | Crane Introduction

2 Safety Device

Load Limit Indicator (LMI)

- The integrated LMI system is provided as standard, ensuring high safety and efficiency in equipment control.
- The LMI system can automatically detect the suspended load weight, working radius of the crane and the angle of boom, and compare rated load weight and actual load, working radius and boom angle. Under normal operation condition, it can intelligently assess risks and automatically cut off crane actions in hazardous directions, and have black box function to record the overload information.
- Its main components include: monitor, controller, length and angle sensor, pressure sensor, etc.

Assembly/working mode switching switch

- The assembly mode is primarily used for scenarios such as the disassembly of the boom or the removal of counterweights. In Assembly Mode, height limit and boom angle limit are disabled to facilitate crane assembly.
- In Work Mode, all safety limiting devices activate to protect the operation.

Emergency Stop

- The left armrest box in cab is equipped with one emergency stop button. In an emergency situation, this button is pressed down to cut off the power supply of the whole machine and all actions stop.

Over-hoist Protection of the Main/Auxiliary Load Hoist

- A2B limit switch is installed on the boom/jib tip, which prevents the hook lifting up too much. When the hook is lifted up to the limit height, the limit switch activates, alarm pops up on the monitor, buzzer on the right front control panel sends alarm, failure indicator light starts to flash and the hook hoisting action is cut off automatically.

Over-release Protection of the Main/Auxiliary Load Hoist

- The 3rd-wrap indicator is installed on main and aux. load hoists to prevent over-release of wire rope. When the rope is paid out close to the last three wraps, the limit switch acts, triggering an alarm through the buzzer and displaying a warning on the monitor, automatically cutting off the winch action.

Function Lock

- There is a function lock lever located on the left side of the driver's seat in the cab. If the function lock lever is not in work position, all the other handles won't work, which prevents any mis-operation caused by accidental hitting.

Hook Latch

- The lifting hook is installed with a baffle plate to prevent wire rope from falling off.

GPS Monitoring System

- Remote monitoring system is a standardized offering to provide functions like GPS locating, GPRS data transfer, machine status inquiry and statistics, operating data monitoring and analysis, remote diagnosis of failures.

Tri-color Load Indicator

- The load indicator light has three colors, i.e., green, yellow and red; and the real time load status is presented on the display. When the actual load is smaller than 90% of rated load, the green light is on; when the actual load is larger than 90% and smaller than 100%, the yellow light is on, the alarm light flashes and sends out continuous sirens; when the actual load reaches 100% of rated load, the red light is on, the alarm light flashes and sends out continuous sirens. At this moment, the system will automatically cut off the crane's dangerous operation.

06 | Crane Introduction

2 Safety Device

Flash Alarm

- When the LMI is powered on, the flash alarm will turn on.

Slewing Indicator Light

- The slewing indicator light flashes during traveling or slewing.

Seat Interlock Protection

- If the operator leaves the seat, all control handles and switches will be disabled immediately to prevent any mis-operation due to accidental collision.

Illuminating Light

- The machine is equipped with low-beam lights in front of the machine, cab lamps, and boom lights, along with lighting devices for night operation, to enhance visibility during operation.

Rear View Mirror

- Rearview mirrors are installed at the front of the operator's cab, on the right-hand platform handrail, and near the winches.

Level Indicator

- The electrical level indicator displays the superstructure's inclination angle on the monitor.

Monitoring System

- Cameras are installed on the winch box, tail of turntable and right side engine cover, which can display real-time monitoring images of the main and auxiliary winches, tail of turntable, and right side track pads on the cab's monitor.

Luffing winch lock device

- Pawl lock is used on boom hoist winch, which needs to unlock by switch before operation, in order to prevent mis-operation of handles and ensure safety during nonwork time.

Slewing lock device

- Slewing Lock can lock the superstructure and lower structure during transportation.

Boom limit device

- When the boom elevation angle reaches the maximum limit, the buzzer sounds and boom operation is cut off. This protection uses a two-stage control system supported by both the LMI system and a travel switch.

Boom angle indicator

- Pendulum angle indicator is fixed on the side of boom base close to the cab, so as to provide convenience to the operator.

07 | Combination

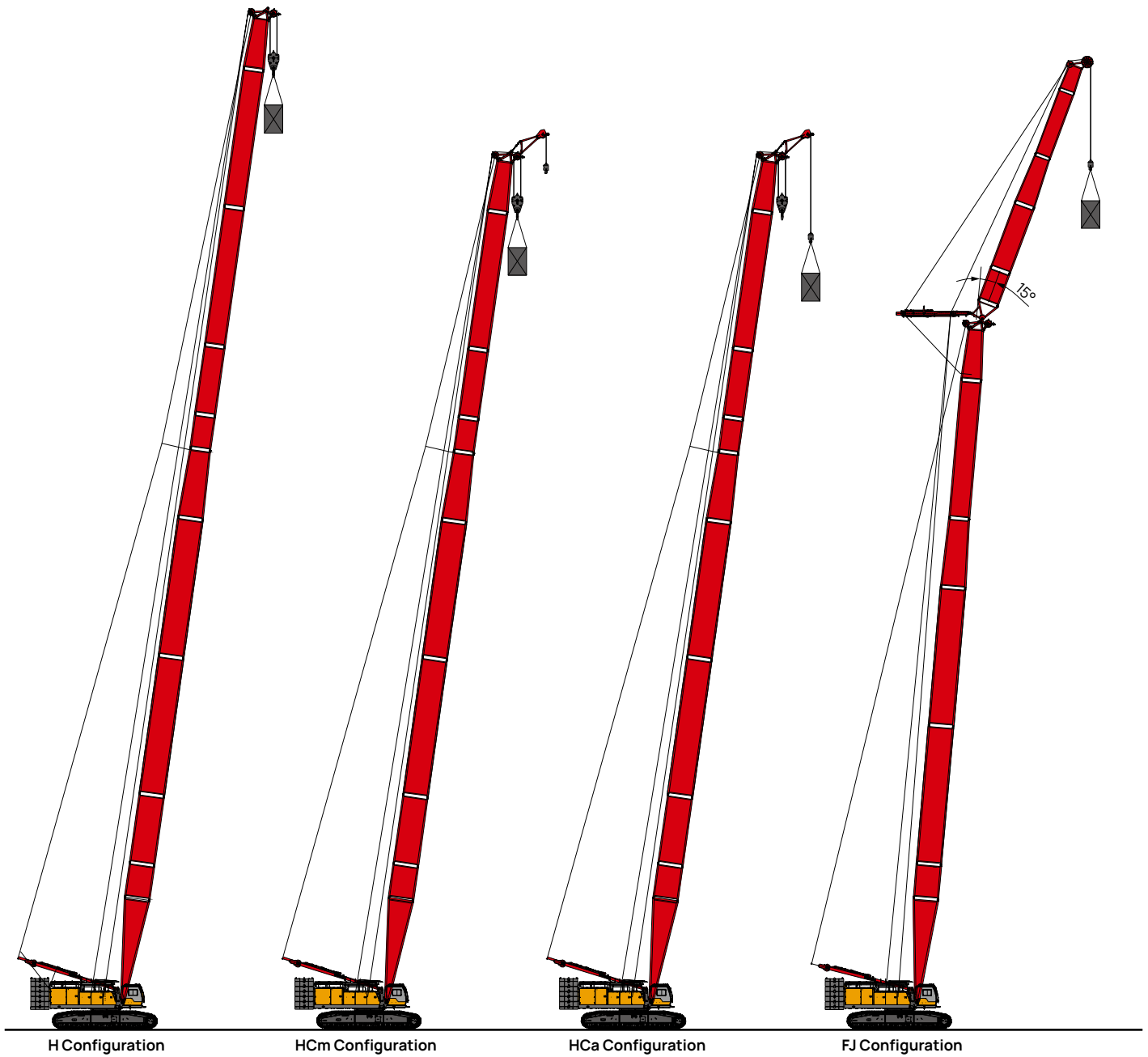

Configuration	Boom Combination	Boom Length
H	Boom (single hook)	20m~86m
HCm	Boom (double hooks, load on main hook)	20m~74m
HCa	Boom (double hooks, load on aux. hook)	20m~74m
FJ	Boom + Fixed jib (single hook)	(20m~59m) + (15m~30m)

Note: The schematics above are reference for loading only.

07 | Combination

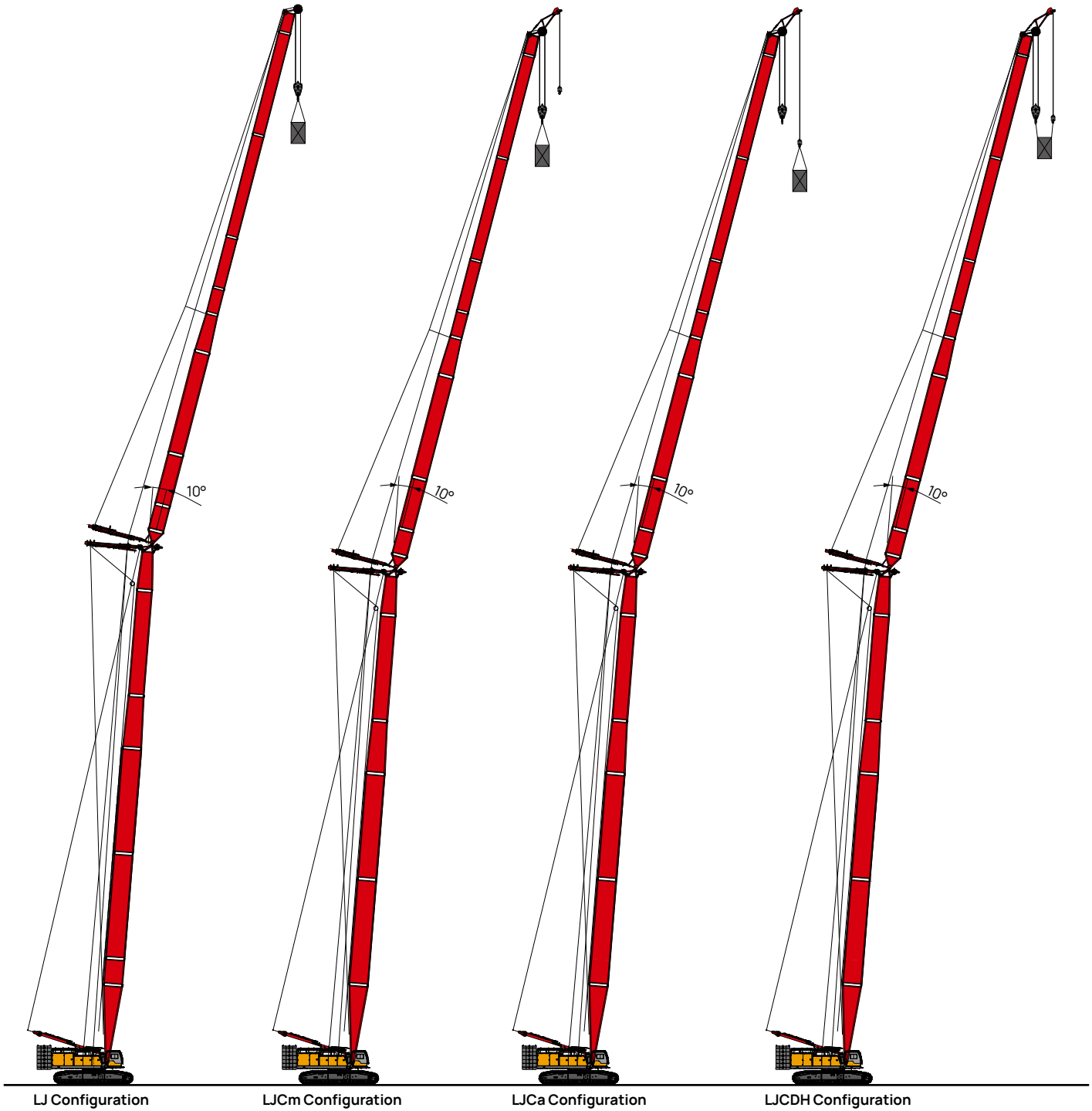

Configuration	Boom Combination	Boom Length
LJ	Boom + Luffing jib (single hook)	(20m~59m)+(18m~63m)
LJCm	Boom + Luffing jib (double hooks, load on main hook)	(20m~56m)+(18m~63m)
LJCa	Boom + Luffing jib (double hooks, load on aux. hook)	(20m~56m)+(18m~63m)
LJCDH	Boom + Luffing jib (double hooks, load on double hooks)	(20m~56m)+(18m~63m)

Note: The schematics above are reference for loading only.

07 | Working Radius

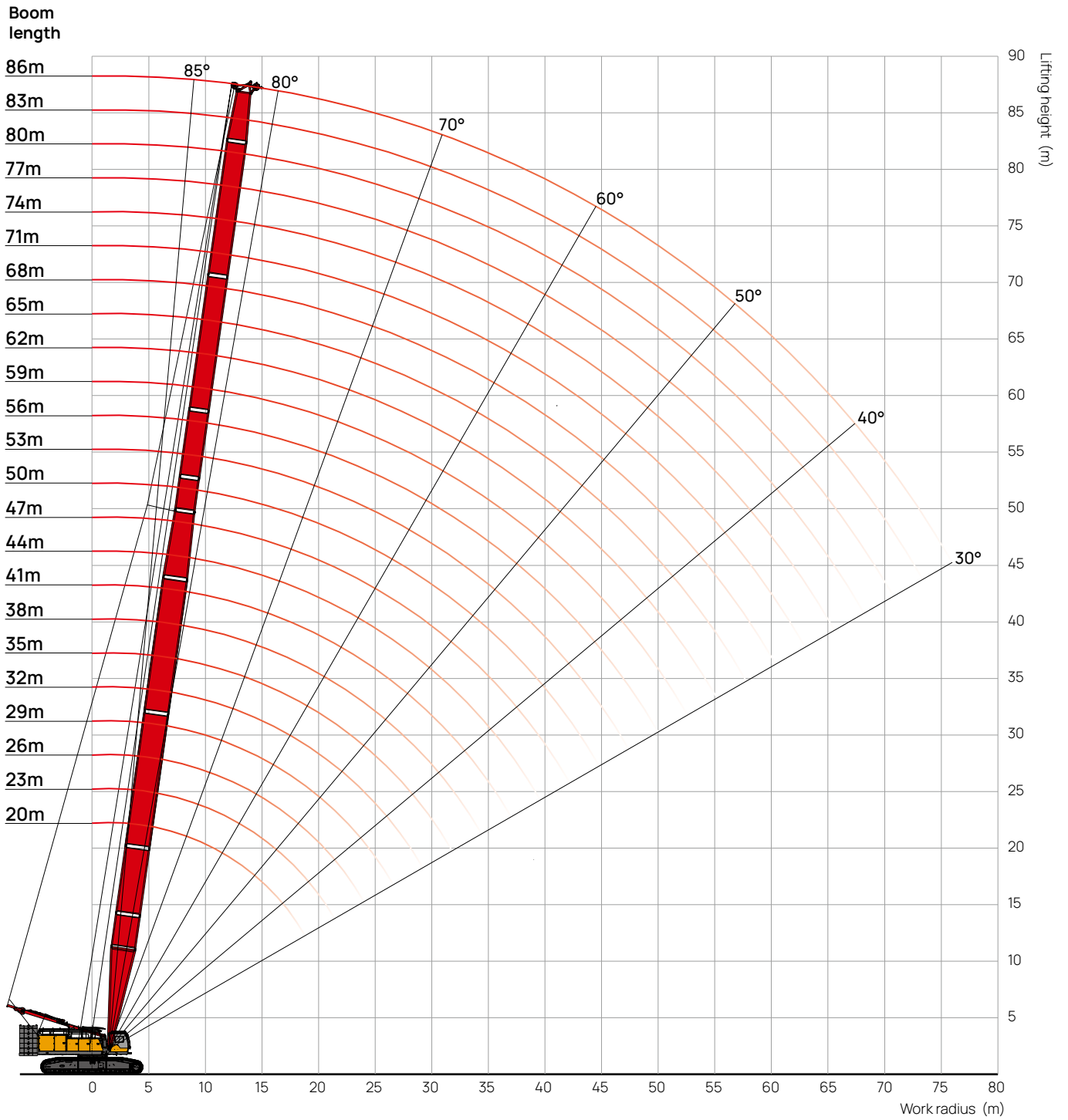

H configuration



07 | Load Chart

H configuration



Unit: t

	Boom Length: 20~86m, Rear Counterweight: 77t, Carbody Counterweight: 20t													
	20	23	26	29	32	35	38	41	44	47	50	53		
5	200	200												5
5.5	200	200	196											5.5
6	200	200	196	172	159									6
7	186	186	186	180	159	147	134	121						7
8	163	163	158	153	148	144	134	121	121	108	95.4			8
9	145	141	137	133	129	125	122	119	116	108	95.4	95.4		9
10	127	124	120	117	114	111	108	106	103	101	95.4	95.4		10
11	110	110	107	105	102	100	97.9	95.6	93.5	91.4	89.3	87.3		11
12	96.9	97	97	94.8	92.9	90.8	88.8	86.8	85.1	83.2	81.5	79.7		12
14	77.6	77.6	77.6	77.6	77.7	76.2	74.6	73.1	71.8	70.4	69	67.6		14
16	64.3	64.4	64.3	64.2	64.4	64.3	64.1	62.9	61.9	60.7	59.5	58.4		16
18	54.6	54.6	54.6	54.5	54.7	54.6	54.4	54.2	54.1	53.1	52.1	51.2		18
20		47.2	47.2	47.1	47.3	47.2	47	46.8	46.8	46.6	46.2	45.3		20
22			41.4	41.3	41.5	41.3	41.2	41	41	40.8	40.5	40.3		22
24			36.6	36.6	36.8	36.6	36.4	36.2	36.2	36	35.8	35.6		24
26				32.6	32.9	32.7	32.6	32.3	32.3	32.1	31.9	31.7		26
28					29.6	29.4	29.3	29.1	29.1	28.9	28.6	28.4		28
30						26.6	26.5	26.3	26.3	26.1	25.9	25.6		30
32						24.2	24.1	23.9	23.9	23.7	23.5	23.2		32
34							22	21.8	21.8	21.6	21.4	21.1		34
36								19.9	20	19.7	19.5	19.3		36
38									18.3	18.1	17.9	17.6		38
40									16.8	16.6	16.4	16.2		40
42										15.3	15.1	14.9		42
44											13.9	13.7		44
46												12.6		46
48														48
50														50
52														52
54														54
56														56
58														58
60														60
62														62
64														64
66														66
68														68
70														70
72														72

07 | Load Chart

H configuration

Unit: t

 m	Boom Length: 20~86m, Rear Counterweight: 77t, Carbody Counterweight: 20t											 m
	56	59	62	65	68	71	74	77	80	83	86	
5												5
5.5												5.5
6												6
7												7
8												8
9	82.2	81.8										9
10	82.2	81.7	75.6	68.8	63	58.7						10
11	82.2	81.1	75	68.8	62.8	58.8	53.5	49	44.9			11
12	78.4	76.8	74.8	68.8	62.1	58.6	53.6	49.1	44.7	41	37.4	12
14	66.7	65.4	64.1	62.8	60.2	58.4	53.4	48.9	44.5	40.4	36.6	14
16	57.7	56.6	55.6	54.5	53.6	52.6	51.5	48.1	43.5	39.5	35.8	16
18	50.7	49.7	48.8	47.9	47.1	46.2	45.3	44.8	42.6	38.6	35	18
20	45	44.2	43.3	42.5	41.8	41.1	40.2	39.8	39	37.7	34.1	20
22	40.3	39.5	38.8	38.1	37.5	36.8	36	35.7	34.9	34.4	33.3	22
24	35.8	35.6	35	34.3	33.8	33.1	32.4	32.1	31.4	31	30.3	24
26	31.9	31.6	31.4	31.1	30.6	30	29.3	29.1	28.4	28	27.4	26
28	28.6	28.4	28.1	27.9	27.7	27.3	26.7	26.5	25.9	25.4	24.8	28
30	25.8	25.6	25.3	25.1	24.9	24.7	24.3	24.2	23.6	23.2	22.6	30
32	23.4	23.2	22.9	22.7	22.5	22.3	22	22	21.6	21.2	20.6	32
34	21.3	21.1	20.8	20.6	20.4	20.2	19.8	19.9	19.6	19.4	18.9	34
36	19.5	19.2	19	18.7	18.6	18.3	18	18.1	17.8	17.6	17.3	36
38	17.8	17.6	17.4	17.1	16.9	16.7	16.4	16.4	16.1	16	15.7	38
40	16.4	16.1	15.9	15.6	15.5	15.2	14.9	15	14.7	14.5	14.2	40
42	15.1	14.8	14.6	14.3	14.2	13.9	13.6	13.7	13.3	13.2	12.9	42
44	13.9	13.7	13.4	13.1	13	12.7	12.4	12.5	12.2	12	11.7	44
46	12.8	12.6	12.3	12.1	11.9	11.6	11.3	11.4	11.1	10.9	10.6	46
48	11.8	11.6	11.4	11.1	10.9	10.7	10.3	10.4	10.1	10	9.6	48
50	10.9	10.7	10.5	10.2	10	9.8	9.4	9.5	9.2	9.1	8.7	50
52		9.9	9.6	9.4	9.2	8.9	8.6	8.7	8.4	8.2	7.9	52
54			8.9	8.6	8.5	8.2	7.9	7.9	7.6	7.5	7.2	54
56				7.9	7.7	7.5	7.1	7.2	6.9	6.8	6.5	56
58				7.2	7.1	6.8	6.5	6.6	6.3	6.1	5.8	58
60					6.5	6.2	5.9	6	5.6	5.5	5.2	60
62						5.6	5.3	5.4	5.1	4.9	4.6	62
64							4.8	4.9	4.5	4.4	4.1	64
66							4.3	4.4	4	3.9	3.6	66
68								3.9	3.6	3.4	3.1	68
70									3.1	3	2.7	70
72										2.6	2.3	72

07 | Boom Combination

FJ configuration

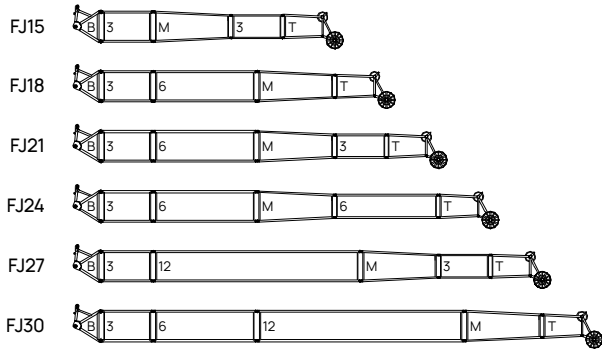

	■ Jib base
	■ Jib tapered insert
	■ Jib top
	■ Jib insert
	■ Jib insert
	■ Jib insert
	■ Jib insert
	■ Jib insert

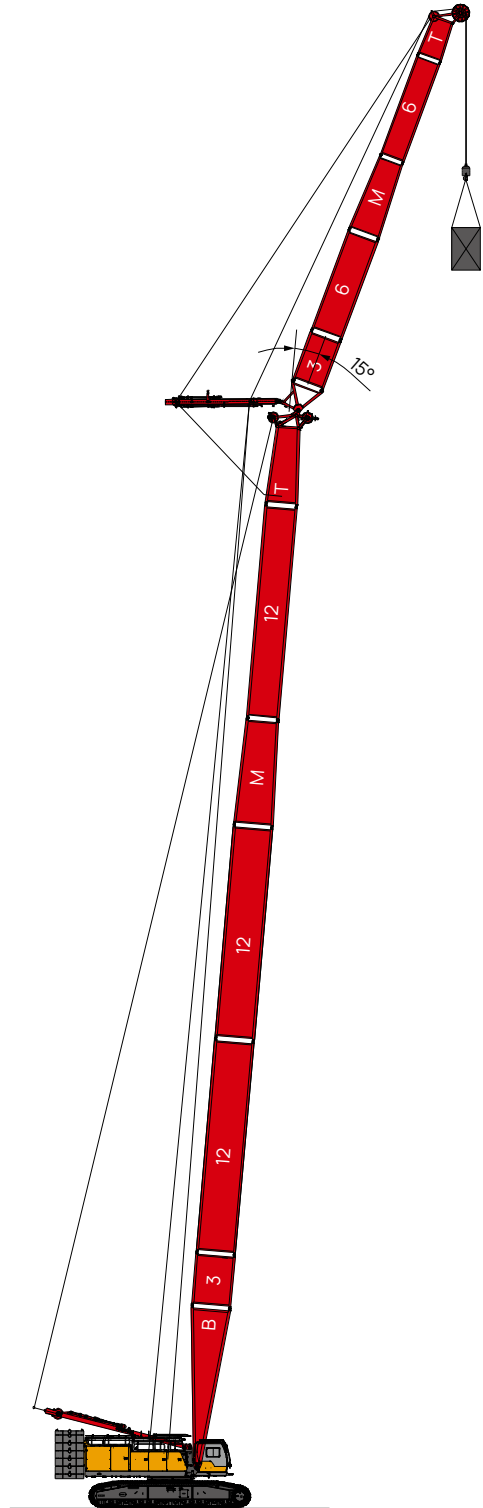

FJ configuration
(20m~59m)+(15m~30m)

07 Working Radius

FJ15 configuration

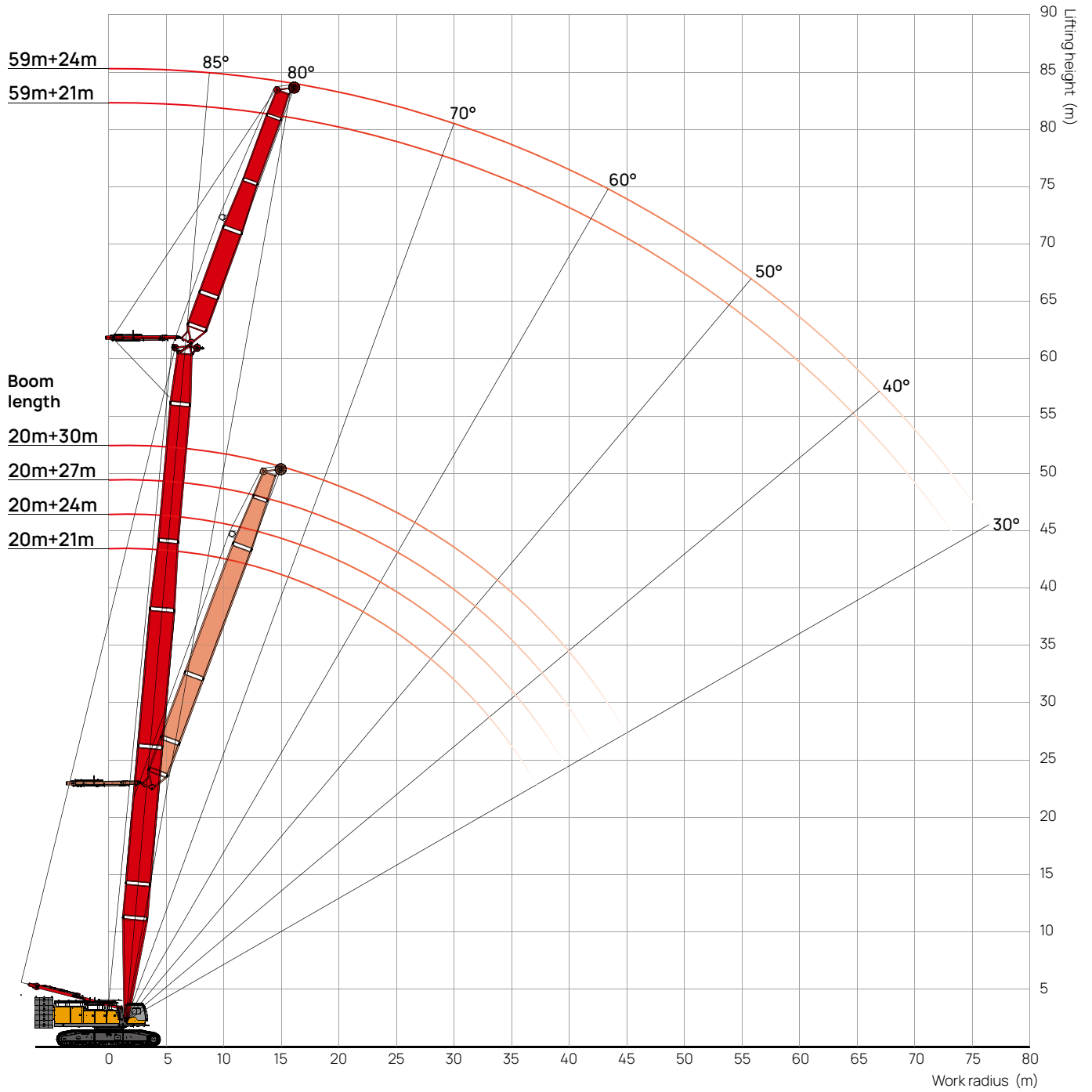

07 | Working Radius

FJ15 configuration

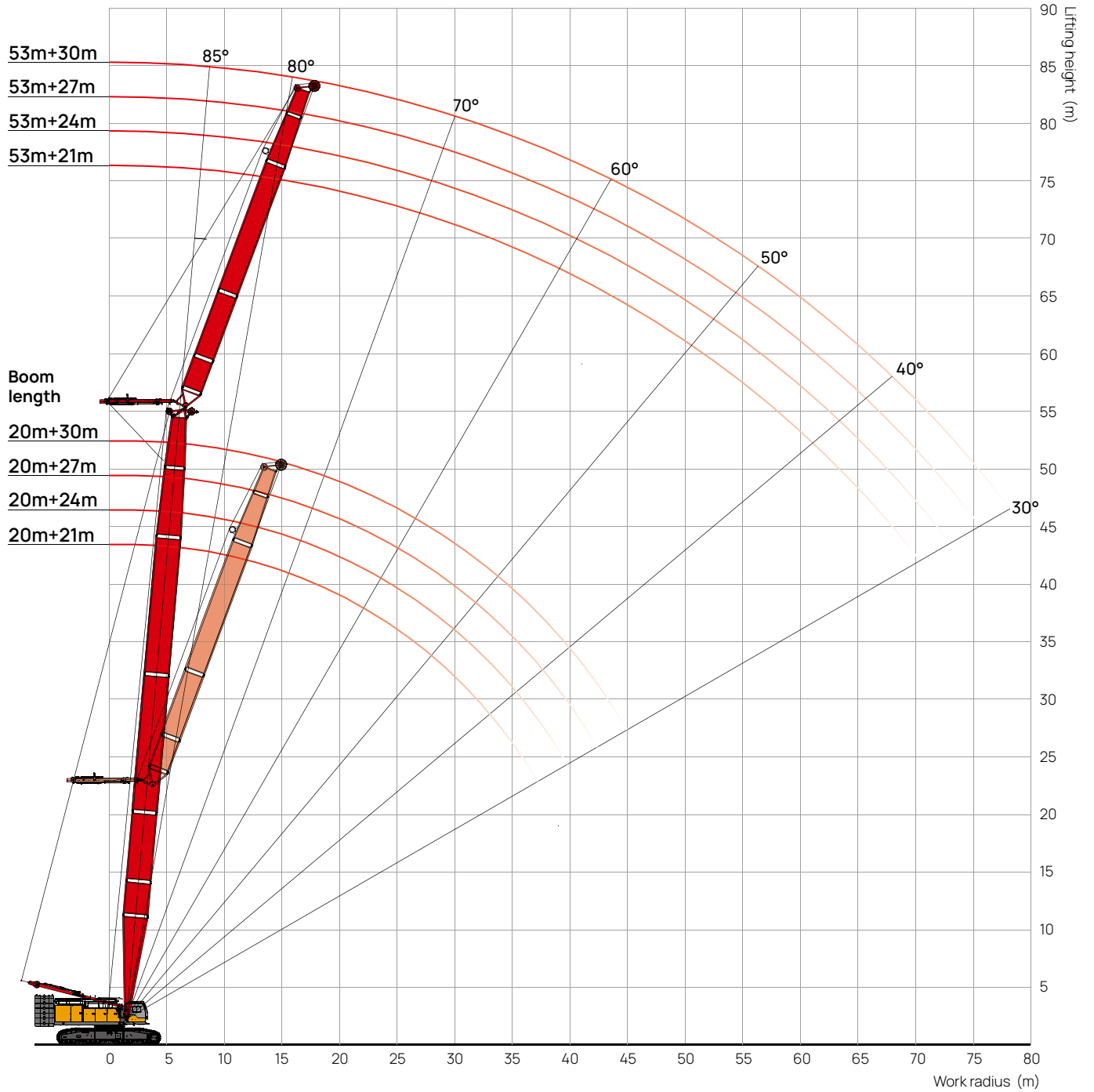

07 | Load Chart

FJ15 configuration

Unit: t

m	Boom Length 20~59m, Jib Length 21m, Boom-Jib Angle 15°, Rear Counterweight 77t, Carbody Counterweight 20t														m
	20	23	26	29	32	35	38	41	44	47	50	53	56	59	
12	34														12
13	32.5	31.2	35.6	38.1											13
14	31	30	34.2	36.9	38.7	39	39	39.2							14
15	29.7	28.9	33.3	35.9	37.5	37.7	37.8	38.1	37.5	36.7	36.4	35.5			15
16	28.4	27.8	32.4	35	36.4	36.4	36.6	37	36.6	35.9	35.6	34.8	23.3	23.1	16
17	27.3	26.8	31.4	34.2	35.1	35.4	35.7	36	35.6	35	34.8	34	22.9	22.6	17
18	26.2	25.8	30.5	33.5	33.9	34.4	34.8	35.1	34.7	34.3	34	33.4	22.5	22.1	18
19	25.2	24.9	29.5	32.6	33.2	33.4	33.9	34.2	34	33.6	33.2	32.7	22.1	21.7	19
20	24.4	24.1	28.6	31.7	32.6	32.5	33	33.3	33.3	33	32.5	32.1	21.7	21.4	20
21	23.5	23.3	27.7	30.9	31.7	31.6	32.1	32.5	32.5	32.3	31.8	31.4	21.2	21	21
22	22.7	22.6	26.9	30.2	30.8	30.8	31.3	31.8	31.9	31.6	31.1	30.8	20.8	20.6	22
23	22	21.9	26.2	29.4	30	30	30.5	31	31.1	30.8	30.6	30.3	20.4	20.2	23
24	21.3	21.3	25.5	28.6	29.2	29.2	29.8	30.3	30.4	30.1	30.1	29.8	20.1	19.9	24
25	20.6	20.7	24.8	27.7	28.5	28.9	29.1	29.6	29.8	29.5	29.5	29.2	19.7	19.6	25
26	20	20.1	24.1	26.9	27.8	28.6	28.4	28.9	29.2	29	29	28.7	19.3	19.3	26
27	19.4	19.5	23.5	26.3	27.1	27.9	27.7	28.3	28.5	28.5	28.4	28.2	19	18.9	27
28	18.8	19	23	25.7	26.5	27.3	27.1	27.7	27.9	28	27.4	26.8	18.7	18.6	28
29	18.3	18.5	22.5	25.1	25.8	26.6	26.7	27	26.8	26.6	26.1	25.5	18.5	18.4	29
30	17.8	18.1	22	24.6	25.2	26	25.8	25.5	25.4	25.2	24.9	24.3	18.3	18.2	30
31	17.3	17.6	21.5	23.9	24.6	24.7	24.5	24.2	24.1	23.8	23.6	23.2	17.9	17.9	31
32	16.9	17.2	21	23.2	23.7	23.5	23.2	23	22.8	22.6	22.4	22.1	17.6	17.7	32
33	16.4	16.8	20.6	22.7	22.6	22.3	22.1	21.8	21.7	21.5	21.2	21	17.4	17.4	33
34	16	16.5	20.2	21.6	21.5	21.2	21	20.7	20.6	20.4	20.1	19.9	17.2	17.2	34
35	15.7	16.1	19.7	20.6	20.5	20.2	20	19.7	19.6	19.4	19.1	18.9	16.9	16.9	35
36	15.4	15.8	19.3	19.6	19.5	19.3	19	18.8	18.6	18.4	18.2	17.9	16.7	16.7	36
37	15.1	15.5	18.9	18.7	18.6	18.4	18.1	17.9	17.7	17.5	17.3	17	16.5	16.5	37
38	14.8	15.2	18.2	17.9	17.8	17.5	17.3	17	16.9	16.6	16.4	16.2	16.2	15.9	38
39	14.6	14.9	17.4	17.1	17	16.7	16.5	16.2	16.1	15.8	15.6	15.3	15.4	15.1	39
40		14.6	16.6	16.3	16.2	16	15.7	15.5	15.3	15.1	14.8	14.6	14.6	14.4	40
41		14.6	15.9	15.6	15.5	15.3	15	14.8	14.6	14.4	14.1	13.9	13.9	13.6	41
42		14.6	15.2	14.9	14.8	14.6	14.3	14.1	13.9	13.7	13.4	13.2	13.2	13	42
43			14.5	14.3	14.2	13.9	13.7	13.4	13.3	13	12.8	12.5	12.5	12.3	43
44			13.9	13.6	13.6	13.3	13.1	12.8	12.7	12.4	12.2	11.9	11.9	11.7	44
45			13.2	13	13	12.7	12.5	12.2	12.1	11.8	11.6	11.3	11.3	11.1	45
46				12.4	12.4	12.2	11.9	11.6	11.5	11.3	11	10.7	10.8	10.5	46
47				11.9	11.9	11.6	11.4	11.1	11	10.7	10.5	10.2	10.2	10	47
48					11.3	11.1	10.8	10.6	10.5	10.2	9.9	9.7	9.7	9.5	48
49					10.8	10.6	10.3	10.1	10	9.7	9.5	9.2	9.2	9	49
50					10.3	10.1	9.9	9.6	9.5	9.2	9	8.7	8.7	8.5	50
51						9.6	9.4	9.1	9	8.8	8.5	8.3	8.3	8	51
52						9.2	9	8.7	8.6	8.3	8.1	7.8	7.9	7.6	52
53							8.5	8.3	8.2	7.9	7.7	7.4	7.4	7.2	53
54							8.1	7.9	7.8	7.5	7.3	7	7	6.8	54
55							7.7	7.5	7.4	7.1	6.9	6.6	6.6	6.4	55
56								7.1	7	6.7	6.5	6.2	6.3	6	56
57								6.7	6.6	6.4	6.1	5.9	5.9	5.6	57
58								6.3	6.2	6	5.8	5.5	5.5	5.3	58
59									5.9	5.7	5.4	5.2	5.2	5	59
60									5.6	5.3	5.1	4.8	4.9	4.6	60
61										5	4.8	4.5	4.6	4.3	61
62										4.7	4.5	4.2	4.3	4	62
63										4.4	4.1	3.9	4	3.7	63
64											3.8	3.6	3.7	3.4	64
65											3.6	3.3	3.4	3.1	65
66												3	3.1	2.9	66
67												2.8	2.8	2.6	67
68												2.5	2.6	2.3	68
69													2.3	2.1	69
70													2.1		70

07 | Working Radius

FJ30 configuration

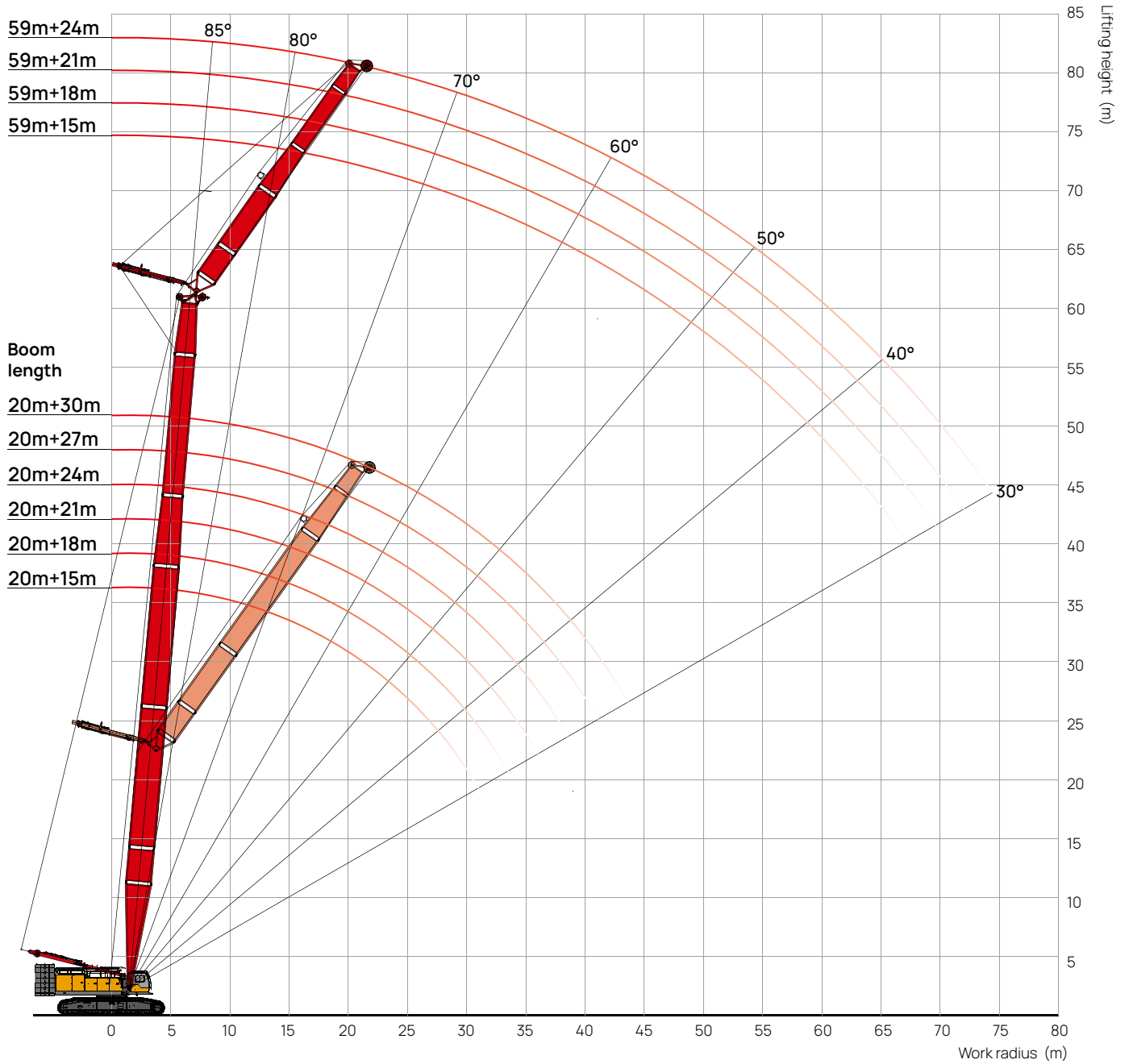

07 | Working Radius

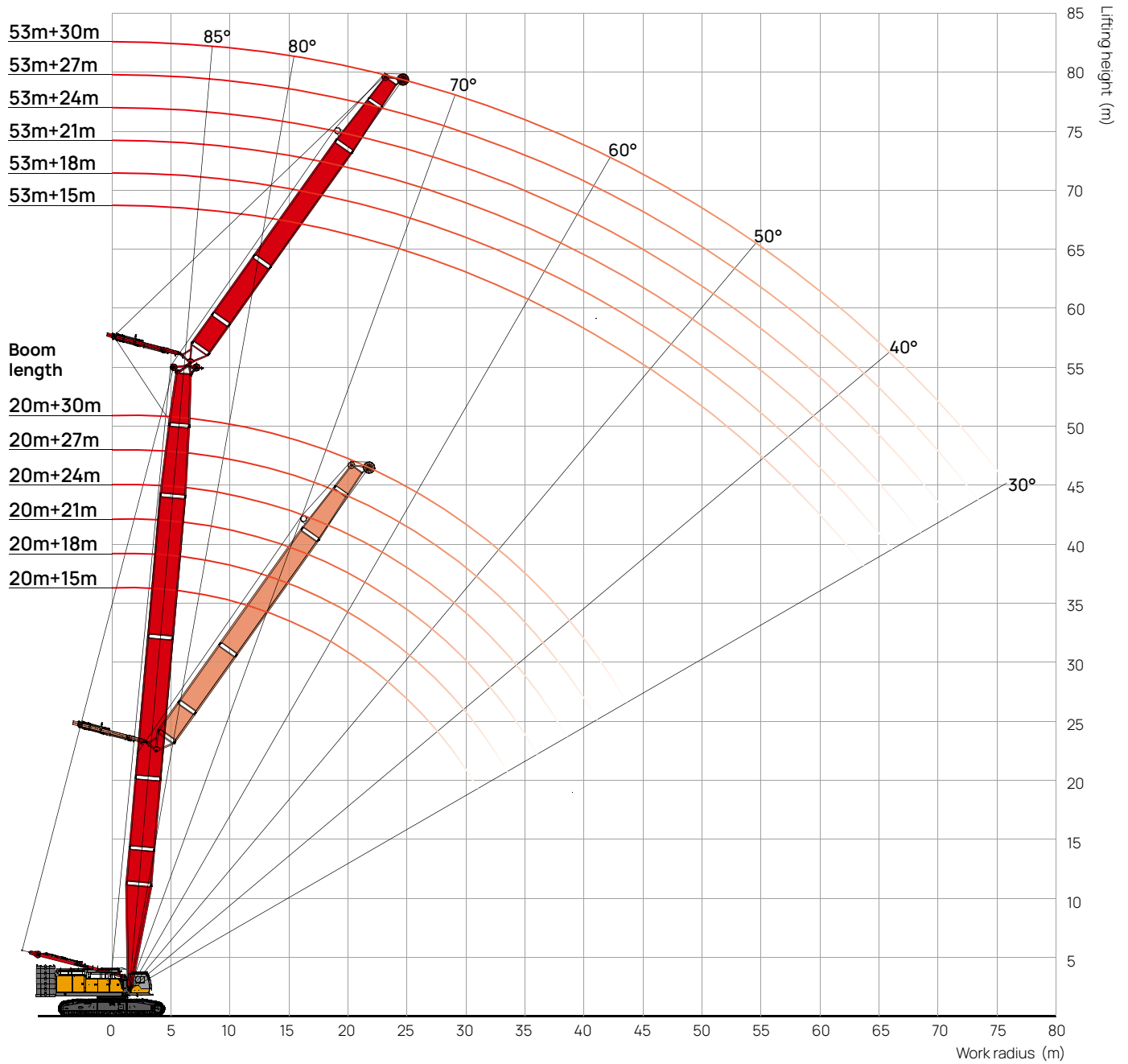

FJ30 configuration



07 | Load Chart

FJ30 configuration

Unit: t

 m	Boom Length: 20~59m, Jib Length: 18m, Boom-Jib Angle: 30°, Rear Counterweight: 77t, Carbody Counterweight: 20t														 m
	20	23	26	29	32	35	38	41	44	47	50	53	56	59	
15	25.2	23.4													15
16	24.5	22.8	26.1	28	30.9	31.4									16
17	23.8	22.2	25.6	27.6	30.5	31	31.8	31.9	31.2						17
18	23.1	21.7	25.2	27.2	30.1	30.7	31.2	31.3	30.7	30.2	29.6	29.2	18.9		18
19	22.5	21.2	24.6	26.8	29.8	30.3	30.6	30.7	30.2	29.6	29.2	28.8	18.6	18.3	19
20	22	20.7	24.1	26.4	29.5	30	30.1	30.2	29.7	29.1	28.8	28.5	18.4	18.1	20
21	21.5	20.2	23.6	26	29.2	29.3	29.5	29.6	29.3	28.8	28.3	28	18.2	17.9	21
22	21	19.8	23.2	25.6	28.9	28.7	29	29.1	28.9	28.5	27.9	27.6	18	17.7	22
23	20.5	19.4	22.7	25.2	28.4	28.3	28.5	28.7	28.4	27.9	27.5	27.2	17.8	17.5	23
24	20	19	22.4	24.8	28	27.9	28	28.3	27.9	27.4	27.2	26.9	17.6	17.4	24
25	19.6	18.6	22	24.4	27.6	27.6	27.5	27.8	27.4	27	26.8	26.5	17.3	17.2	25
26	19.2	18.3	21.6	24	27.2	27.4	27.1	27.4	27	26.7	26.4	26.1	17.1	17	26
27	18.8	17.9	21.3	23.6	26.7	26.9	26.8	27.1	26.7	26.3	26.1	25.8	16.9	16.8	27
28	18.5	17.6	21	23.3	26.2	26.5	26.5	26.8	26.4	26	25.8	25.5	16.8	16.7	28
29	18.1	17.3	20.6	23	25.7	26.2	26.1	26.4	26	25.6	25.5	25.2	16.6	16.5	29
30	17.8	17.1	20.2	22.7	25.2	25.9	25.7	26	25.7	25.3	25.2	24.9	16.5	16.4	30
31	17.5	16.8	19.9	22.4	24.9	25.1	24.9	24.7	24.6	24.5	24.3	24.1	16.3	16.2	31
32	17.3	16.6	19.7	22.1	24	23.8	23.6	23.4	23.4	23.2	23	22.8	16.2	16.1	32
33	17.1	16.4	19.5	21.8	22.8	22.6	22.4	22.2	22.2	22	21.8	21.6	16	15.9	33
34	16.9	16.2	19.3	21.5	21.7	21.5	21.3	21.1	21	20.9	20.7	20.5	15.9	15.7	34
35	16.7	16	19.1	20.7	20.7	20.5	20.3	20.1	20	19.8	19.6	19.4	15.7	15.6	35
36	16.7	15.9	18.9	19.7	19.7	19.5	19.3	19.1	19	18.8	18.6	18.4	15.6	15.6	36
37	16.7	15.8	18.7	18.8	18.8	18.6	18.4	18.2	18.1	17.9	17.7	17.5	15.5	15.5	37
38		15.7	18.1	17.9	17.9	17.7	17.5	17.3	17.2	17	16.8	16.6	15.4	15.4	38
39		15.7	17.2	17	17	16.9	16.7	16.5	16.4	16.2	16	15.8	15.3	15.3	39
40			16.4	16.2	16.2	16.1	15.9	15.7	15.6	15.4	15.2	15	15	14.8	40
41			15.6	15.5	15.5	15.3	15.1	14.9	14.8	14.6	14.4	14.2	14.3	14.1	41
42			14.8	14.7	14.8	14.6	14.4	14.2	14.1	13.9	13.7	13.5	13.6	13.4	42
43				14	14.1	13.9	13.7	13.5	13.5	13.2	13	12.8	12.9	12.7	43
44				13.3	13.4	13.3	13.1	12.9	12.8	12.6	12.4	12.2	12.2	12	44
45				12.6	12.8	12.6	12.5	12.3	12.2	12	11.8	11.6	11.6	11.4	45
46					12.1	12	11.9	11.7	11.6	11.4	11.2	11	11	10.8	46
47					11.5	11.4	11.3	11.1	11	10.8	10.6	10.4	10.5	10.3	47
48						10.9	10.7	10.5	10.5	10.3	10.1	9.9	9.9	9.7	48
49						10.3	10.2	10	10	9.8	9.6	9.3	9.4	9.2	49
50						9.8	9.7	9.5	9.5	9.3	9.1	8.8	8.9	8.7	50
51							9.2	9	9	8.8	8.6	8.4	8.4	8.2	51
52							8.7	8.5	8.5	8.3	8.1	7.9	8	7.8	52
53								8.1	8.1	7.9	7.7	7.5	7.6	7.3	53
54								7.6	7.6	7.4	7.3	7	7.1	6.9	54
55								7.2	7.2	7	6.8	6.6	6.7	6.5	55
56									6.8	6.6	6.4	6.2	6.3	6.1	56
57									6.4	6.2	6	5.8	5.9	5.7	57
58									6	5.8	5.7	5.5	5.6	5.4	58
59										5.5	5.3	5.1	5.2	5	59
60										5.1	4.9	4.7	4.9	4.7	60
61											4.6	4.4	4.5	4.3	61
62											4.2	4.1	4.2	4	62
63											3.9	3.7	3.9	3.7	63
64												3.4	3.6	3.4	64
65												3.1	3.3	3.1	65
66													3	2.8	66
67														2.7	67
68														2.4	68

07

Working Radius

LJ configuration

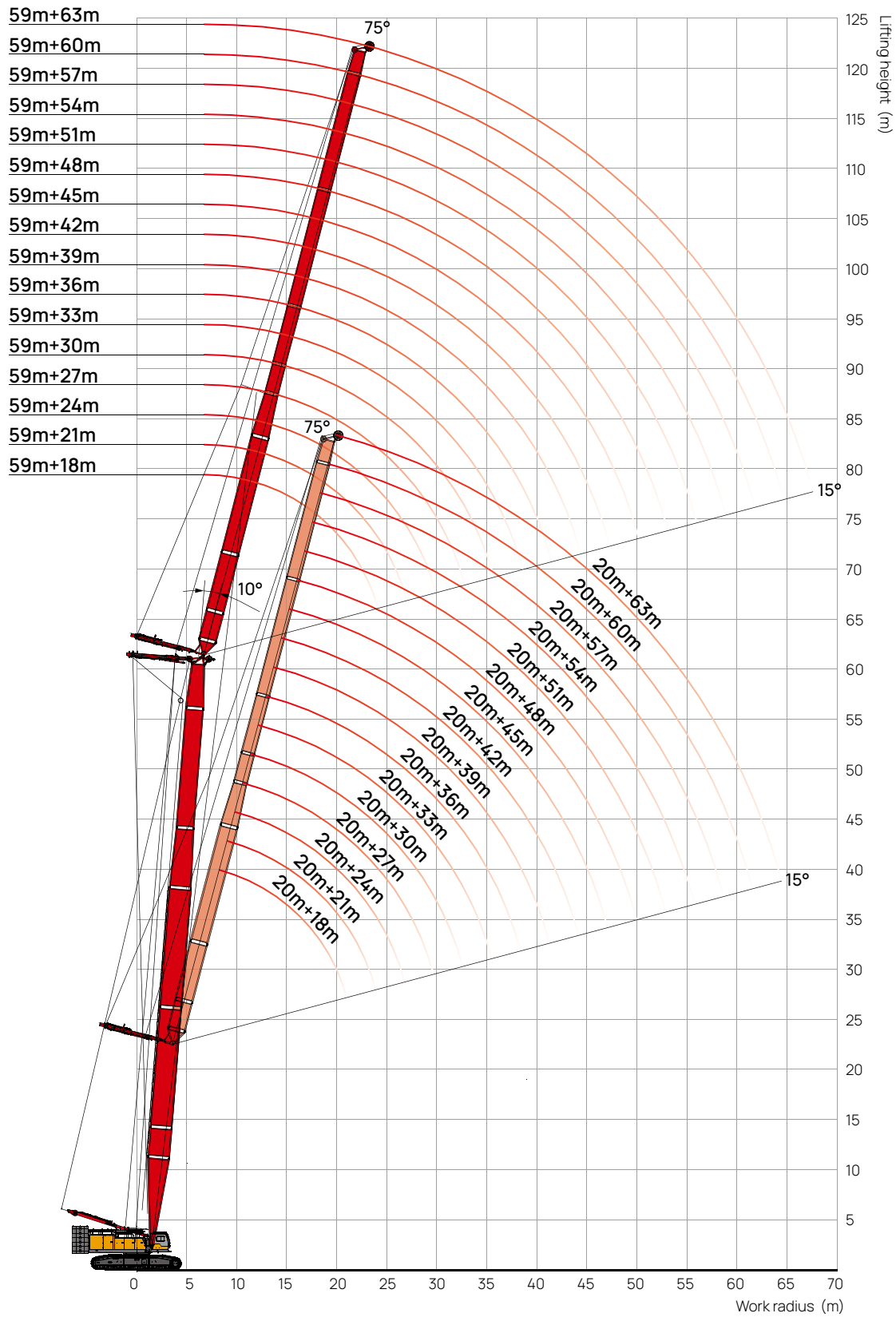

07 | Load Chart

LJ configuration

Unit: t

m	Boom Length: 41m, Boom Angle: 85°, Jib Length: 18~63m, Rear Counterweight: 77t, Carbody Counterweight: 20t																m
	18	21	24	27	30	33	36	39	42	45	48	51	54	57	60	63	
12	73.8	70.9															12
13	69.5	67.2	61.1														13
14	65.3	63.5	61.1	59.2													14
15	61.9	60.3	58.3	56.3	51.6	49.8											15
16	58.5	57.2	55.5	53.4	51.6	49.8	47.8										16
17	55.7	54.4	52.8	51.0	49.3	47.5	46.0	42.6									17
18	52.9	51.6	50.2	48.8	47.0	45.4	44.3	42.6	39.8	36.1							18
19	50.4	49.3	48.0	46.7	45.0	43.7	42.5	40.1	39.5	35.9	32.5						19
20	47.8	47.0	45.9	44.7	43.1	42.0	40.7	37.6	38.1	35.7	32.5	29.4					20
21	44.5	44.8	44.0	42.8	41.4	40.3	38.6	35.6	36.7	35.4	32.3	29.2	26.4				21
22	41.6	41.9	42.1	41.0	39.8	38.7	36.5	33.6	35.3	34.7	32.1	29.1	26.4	23.8	21.5		22
23	39.0	39.3	40.1	39.5	38.3	37.1	34.7	31.8	33.7	33.4	31.5	28.9	26.2	23.7	21.4	19.2	23
24		37.0	37.8	37.6	36.9	35.6	33.0	30.1	32.1	32.2	30.8	28.7	26.1	23.6	21.3	19.2	24
25		34.9	35.6	35.4	35.1	33.9	31.2	28.6	30.6	31.3	30.0	28.4	25.9	23.4	20.9	18.8	25
26		33.0	33.7	33.5	33.2	32.2	29.5	27.1	29.2	30.4	29.3	28.2	25.7	23.1	20.4	18.5	26
27			32.0	31.8	31.5	30.6	28.2	25.8	27.8	29.4	28.5	27.5	25.5	22.7	20.0	18.0	27
28			30.4	30.2	29.9	29.0	26.9	24.6	26.5	28.4	27.7	26.7	25.3	22.3	19.7	17.5	28
29				28.7	28.4	27.7	25.6	23.5	25.3	27.6	26.9	25.6	25.1	21.9	19.2	17.1	29
30				27.4	27.1	26.4	24.4	22.4	24.2	26.8	26.0	24.5	24.5	21.6	18.9	16.8	30
31				26.2	25.8	25.3	23.2	21.4	23.1	25.6	25.0	23.5	23.5	21.3	18.6	16.5	31
32					24.7	24.3	22.2	20.4	22.0	24.4	24.0	22.5	22.6	21.0	18.3	16.2	32
33					23.6	23.3	21.2	19.5	21.1	23.4	23.1	21.5	21.8	20.6	17.9	15.9	33
34					22.6	22.3	20.2	18.6	20.2	22.4	22.2	20.6	21.0	20.2	17.6	15.6	34
35						21.4	19.4	17.8	19.3	21.4	21.4	19.8	20.2	19.5	17.3	15.3	35
36						20.5	18.7	17.1	18.5	20.6	20.5	19.1	19.4	18.9	17.1	15.0	36
37						20.0	17.8	16.3	17.8	19.8	19.7	18.4	18.7	18.2	16.8	14.7	37
38							17.0	15.6	17.1	19.0	18.9	17.7	18.2	17.6	16.5	14.5	38
39							16.4	14.9	16.4	18.3	18.2	17.0	17.5	17.0	16.2	14.2	39
40							15.8	14.3	15.7	17.6	17.6	16.3	16.8	16.4	15.9	14.0	40
41								14.3	15.1	17.0	16.9	15.7	16.2	15.8	15.4	13.8	41
42								14.3	14.5	16.4	16.3	15.1	15.6	15.3	14.9	13.6	42
43								14.3	13.9	15.8	15.8	14.5	15.0	14.8	14.4	13.4	43
44									13.4	15.3	15.2	14.0	14.4	14.3	13.9	13.2	44
45									13.4	14.8	14.7	13.5	13.9	13.9	13.5	12.9	45
46									13.4	14.3	14.2	13.1	13.4	13.5	13.1	12.6	46
47										13.8	13.8	12.6	12.9	13.0	12.7	12.2	47
48										13.4	13.3	12.2	12.5	12.5	12.3	11.9	48
49										13.0	12.9	11.7	12.1	12.0	11.9	11.5	49
50											12.5	11.3	11.7	11.6	11.5	11.2	50
51											12.1	10.9	11.3	11.2	11.1	10.8	51
52											11.7	10.5	10.9	10.8	10.7	10.4	52
53												10.5	10.5	10.4	10.3	10.0	53
54												10.5	10.2	10.1	9.9	9.6	54
55												10.5	9.8	9.7	9.5	9.2	55
56													9.5	9.4	9.2	8.8	56
57													9.5	9.0	8.8	8.5	57
58														8.7	8.5	8.2	58
59														8.4	8.2	7.9	59
60														8.1	7.9	7.6	60
61															7.9	7.3	61
62															7.9	7.0	62
63															7.9	6.7	63
64																6.5	64
65																6.5	65
66																6.5	66

Zhejiang Sany Equipment Co.,LTD

SANY Crawler Crane Industrial Park, No. 2188 Daishan Road, Wuxing District, Huzhou City, Zhejiang Province, P. R. China Zip 313028
Consulting sanycrane@sanygroup.com (Crane BU) / crd@sany.com.cn (IHQ)
After-sales Service 0086-400 6098 318

Reminder:

Any change in the technical parameters and configuration due to product modification or upgrade may occur without prior notice.
The machine in the picture may include additional equipment. This brochure is for reference only, and goods in kind shall prevail.
Copyright at SANY. No part of this brochure may be copied or used for any purpose without written approval from SANY.

© Edited in February 2025

